

MADDEN PUMP

CHEMICAL FEED SYSTEMS



- ❖ Chemical feed systems that combine on one platform, a holding tank for mixing and storing chemical solutions, a mixer, a Madden diaphragm metering pump to inject the chemical solution, and suction and relief piping. Standard pre-engineered systems are available, as well as customized systems with equipment and features specified by the end user.



- Pg 1 **PART NUMBERING FORMAT**
- Pg 2 **FEATURES & COMMON APPLIATIONS**
- Pg 3 **GA PRINTS FOR GENERIC COMPACT SYSTEMS**
- Pg 4 **GA PRINTS FOR GENERIC BOILER WATER TREATMENT SYS'S**
- Pg 5 **CUSTOM OPTIONS & DOSING ONLY SKIDS (No tank or mixer)**

MADDEN CHEMICAL FEED SYSTEM PART NUMBERING TREE

Material	Pump Output (GPH)	Optional Ancillary Eq.
P - HDPE	02	1 - Variable Frequency Drive
S - Stainless Steel	05	2 - Toggle Switch & Cord
	07	3 - Tank Level Switch & Alarm
	11	4 - Flow Meter & Display
Tank Size (Gallons)	Pump Quantity	5 - Pressure Gauge
055	Up to 4	6 - Pulsation Dampener
110	Mixer	7 - Back Pressure Valve
125	AH	8 - 316SS Pump & Discharge
250	AM	
350		

Full P/N Example:

CFP055	021AH	23
--------	-------	----

PRE-DESIGNED CHEMICAL FEED SYSTEMS

"Generic, Compact Designs" - Model No's:

CFP055-02_AH-(TBD)

CFP110-02_AH-(TBD)

"Boiler Water Treatment Designs" - Model No's:

CFP125-02_AH-(TBD) - Boiler Rooms Producing 0-50 KPPH

CFP250-05_AM-(TBD) - Boiler Rooms Producing 50-100 KPPH

CFP350-07_AM-(TBD) - Boiler Rooms Producing 100-250 KPPH

Standard Items in our Compact Designs:

- JN102 Diaphragm Metering Pump
- AH1B1 High Speed Mixer
- Pressure Relief Valve
- Piping: Rigid PVC, 1/4" ID w/ Sch 80 Threaded Fittings Piping
- Platform: steel platform elevates system 16" above ground. Includes 1/2" bolt holes in foot pads.

Standard Items in our Boiler Water Treatment Designs:

- (2) JN Series Diaphragm Metering Pumps, plumbed for duty/standby operation
- For the 125g system, the AH1B1 mixer is standard, for the 250g and 350g designs change to AM1B3 medium speed with a bridge type mounting support.
- (2) Pressure Relief Valves
- Calibration column and Y strainer on suction line
- Piping: Rigid PVC, 1/4" ID w/ Sch 80 Threaded Fittings Piping

Available Optional Adders:

- 304SS tanks
- 316SS piping with FNPT or Swagelok Compression fittings
- 316SS pump solution head for 300 PSI applications (Optional Ancillary Item 8)
- Larger Madden Pumps (MF and MH Series, up to 360 GPH)
- Additional ancillary equipment on discharge line (see above)

DESIGN NOTE (Pressure): All Madden chemical feed systems are designed to inject into ≤ 150 PSI applications. Systems can be modified to reach up to 300 PSI by changing out the standard PVC pump solution head and discharge piping to 316SS for an added cost.

GENERIC, COMPACT DESIGNS - FEATURES

The Madden compact chemical feed systems are designed to be simple, durable and effective, all while taking up less than 3 sq. ft. of floor space. The main features are as follows:

- **TANKS:** durable polyethylene tanks are standard. Stainless steel tanks are optional. Hinged lids and piping connections are included. Tanks are translucent, rated to 140 deg F. Standard sizes are 55 gallon and 110 gallon.
- **PUMPS:** Madden diaphragm metering type pumps are used to inject chemicals into the plant operating system. Madden pumps are industrial grade, heavy duty construction, with adjustable output control. Our JN102 pump is the standard model, other sizes are optional. See the JN21 data sheet for more details.
- **MIXERS:** Madden high speed mixers are used to mix the chemical solution needed. Stainless steel shaft and propeller are standard. See the Madden mixer brochure for complete mixer details.
- **PLATFORMS:** welded steel construction designed to support the filled tank, and serve as a mounting for the mixer, pump and piping. Platforms elevate the tank 16" above the ground for easy operator access. Standard finish is acrylic gray enamel, with highly corrosion resistant epoxy primer with polyurethane top coat as an option.
- **PIPING:** standard pipe is 1/4" ID, Sch 80 PVC with FNPT Sch 80 PVC fittings. Includes a foot valve and strainer on the suction line and a pressure relief valve on the discharge.
- **APPLICATIONS:** these compact systems have been sold by Madden for over 60 years. The part numbers were previously TE502 and TE503. They are used in many industries including food processing, boiler rooms, wastewater treatment, and more.

BOILER WATER TREATMENT DESIGNS - FEATURES

The Madden boiler room focused chemical feed system designs include the following features:

- **TANKS:** durable polyethylene cone bottom tanks are standard. Stainless steel tanks are optional. Hinged lids and piping connections are included. Tanks are translucent, rated to 140 deg F. Standard sizes are 125, 250, and 350 gallon.
- **PUMPS:** Madden diaphragm pumps as mentioned above. Our JN105, 107, and 111 models are also included in this lineup.
- **MIXERS:** Madden high speed mixers are used for the 125 gallon design. For the 250 and 350 gallon designs we use our medium speed mixer with a bridge type mounting support.
- **SKIDS:** Systems come pre-installed on 4' x 8' steel skid tops with a 3" 5# C channel frame. Skids include holes for securing to floor and are finished with grey acrylic paint.
- **PIPING:** standard piping is the same as the above.
- **APPLICATIONS:** these designs can be used for any chemical injection application, but they are specifically tailored to boiler rooms with the following capacities:
 - 125 Gallon – Boiler rooms producing up to 50,000 PPH of steam.
 - 250 Gallon – Boiler rooms producing 50,000 to 100,000 PPH of steam.
 - 350 Gallon – Boiler rooms producing 100,000 to 250,000 PPH of steam.

GENERIC, COMPACT DESIGN

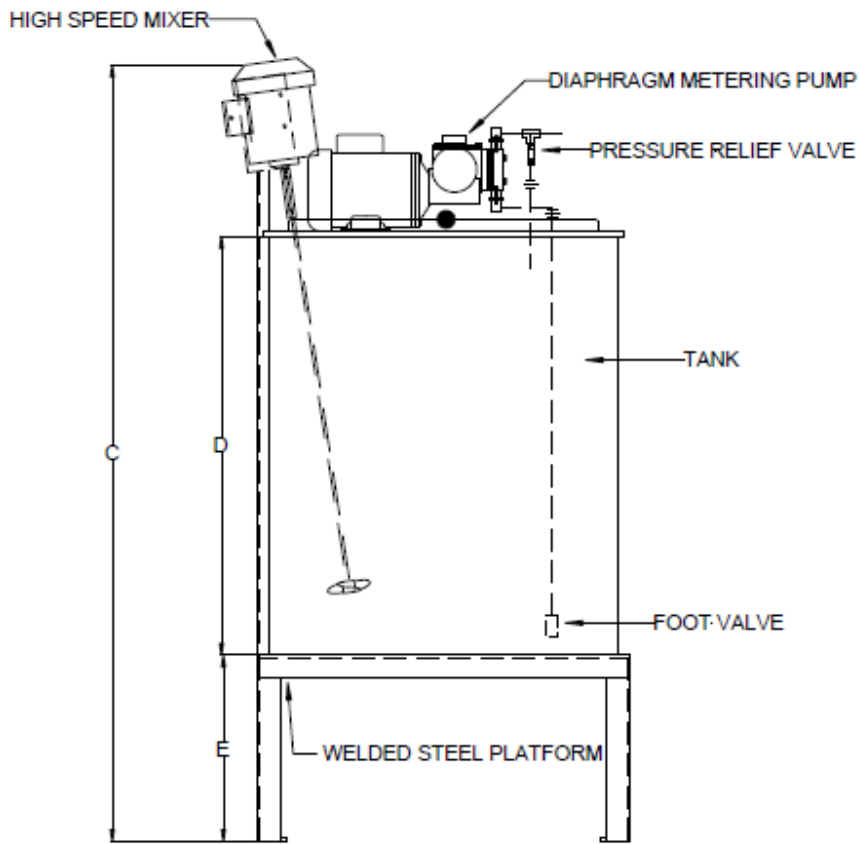
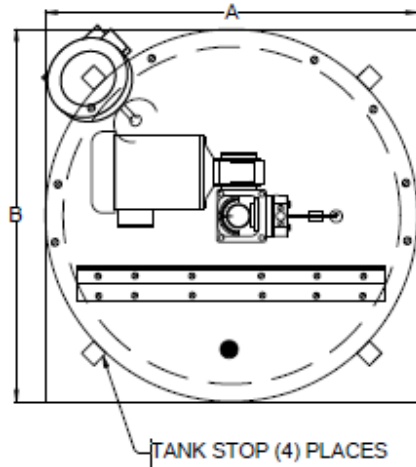

MODEL NUMBER	TANK CAPACITY (Gal.)	TANK MATERIAL	A	B	C	D	E
CFP055-021AH-(TBD)	55	HDPE	24"	24"	68"	36"	16"
CFP110-021AH-(TBD)	110	HDPE	32"	32"	68"	36"	16"

TYPICAL BOILER WATER TREATMENT DESIGN

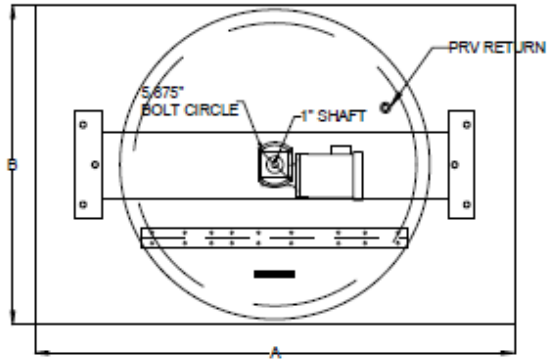

VISUAL REFERENCE - PUMPS INSTALLED UNDER TANK

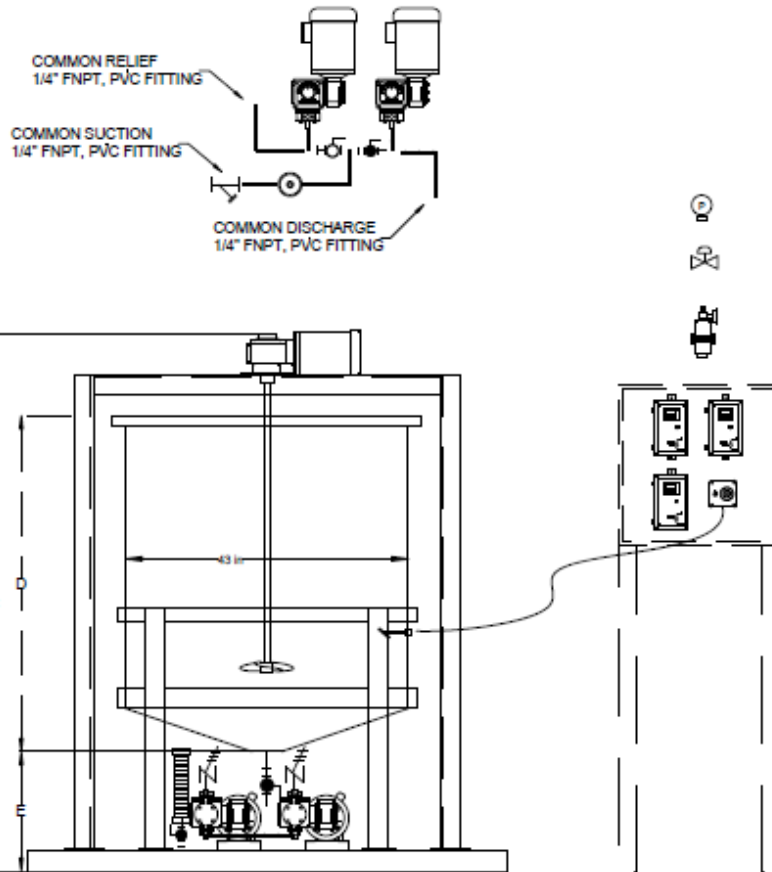

MODEL NUMBER	TANK CAPACITY (Gal.)	TANK MATERIAL	A	B	C	D	E
CFP125-022AH-(TBD)	125	HDPE	48"	48"	62"	30"	18"
CFP250-052AM-(TBD)	250	HDPE	72"	48"	81"	49"	18"
CFP350-052AM-(TBD)	350	HDPE	72"	48"	97"	67"	18"

CUSTOMER SPECIFIED OPTIONS

For those customers with special requirements for a chemical feed system Madden is ready to modify the standard systems shown above, or start from scratch with a complete new layout. Here are some of the features we frequently get requests to include in a chemical feed system:

- Tank level switch
- Electrical control box, including wiring in flexible conduit to each motor
- Pipe, valve and fitting features specified by the customer
- Motors: standard motors are TEFC 1/60/115-230 or 3/60/230-460. Optional motors are available for 50 HZ electric power, or special enclosure requirements
- Calibration column to measure pump output
- Duplex systems with two pumps, one for service and one for backup
- Pump materials of construction specified by the customer
- Flow meter, automatic pump flow control

DOSING STATIONS

Planning to use premixed chemical totes for your chemical injection application? No problem, we also make simple dosing skids without a holding tank and mixer. These compact skids are designed to have a 55 gallon drum or 4' x 4' x 4' chemical tote set next to them and then connected to our dosing skid with a quick connect. Let us know the ancillary equipment you prefer and the quick connect type and we'll get to work. Examples Below:



MADDEN
PUMP

1317 Princeton Blvd. • Elkhart, IN 46516
Phone (574) 295-4292 • Fax (574) 295-7562
Email: info@maddenpump.com • Website: www.maddenpump.com →

