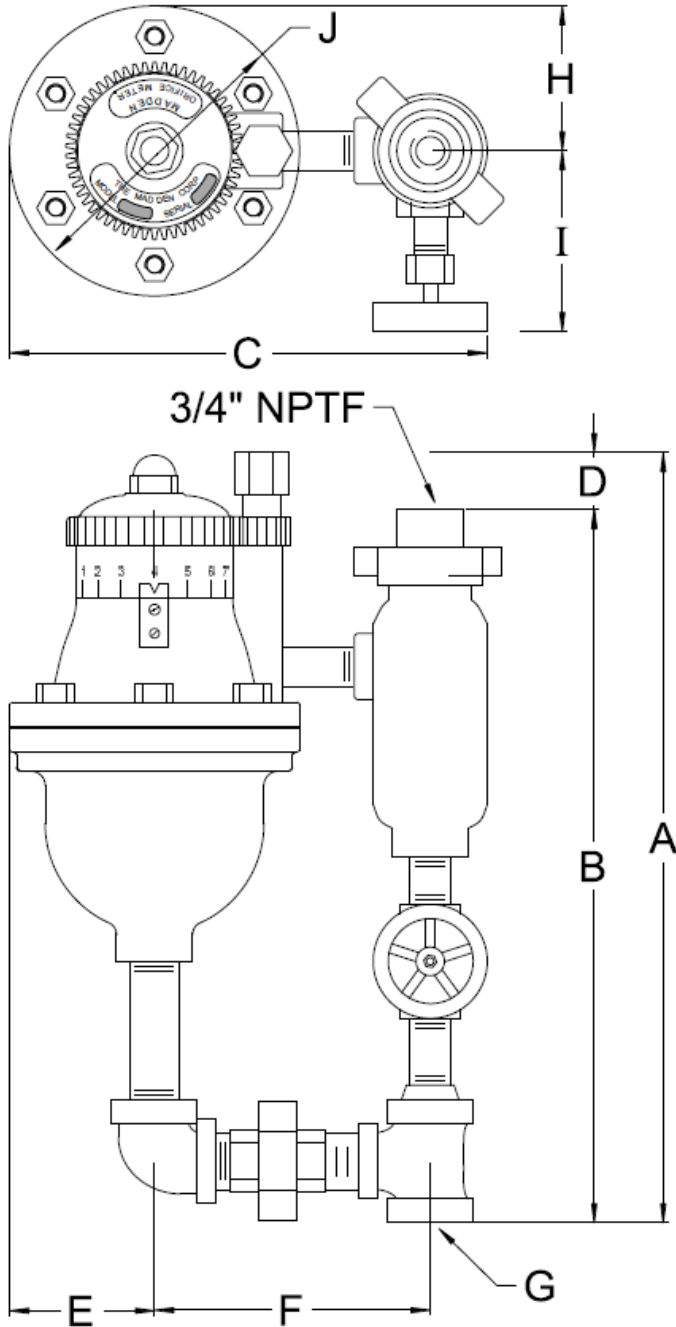

**TABLE OF CONTENTS**

- General Arrangement Drawing..... Pg 2
- Parts List..... Pg 3
- Installation Instructions..... Pg 4
- Operating Tips..... Pg 5
- Hot Torque Instructions.....Pg 6

## General Arrangement Drawing



MODEL:	<b>OM250_A</b>	<b>OM650_A</b>
A	18-3/4"	20-1/4"
B	18"	19-1/4"
C	11-1/2"	14"
D	1-1/8"	1-3/8"
E	3-1/2"	3-3/4"
F	6-1/2"	7-1/4"
G	1"	1-1/4"
H	3-1/2"	3-3/4"
I	5-1/2"	8-3/4"
J	7-1/8"	7-1/2"
NET WEIGHT	55 LBS	68 LBS
SHIPPING WEIGHT	64 LBS	80 LBS

# Orifice Meter Parts List

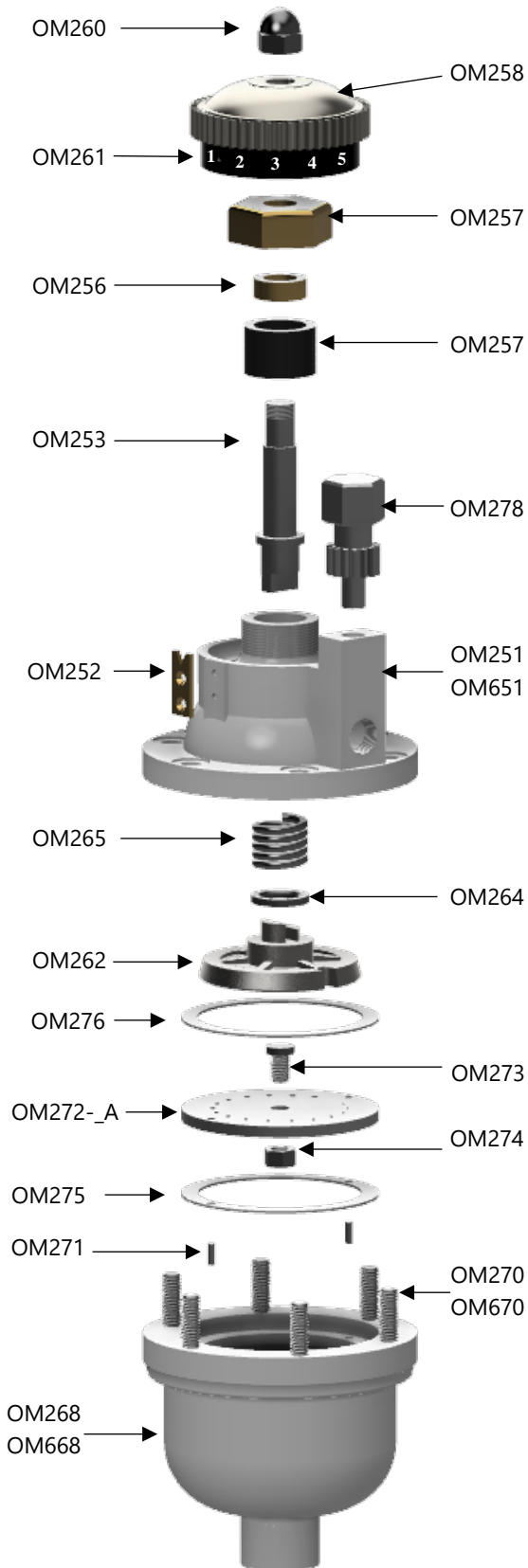

MODEL NO. OM250	MODEL NO. OM650	Description
Part No.	Part No.	
OM251	OM651	Top Body Casting
OM252	OM252	Orifice Indicator – Bronze Plate
OM253	OM253	Stem for Rotating Disc
OM255	OM255	Packing for Stem (5 req'd)
OM256	OM256	Ring for Packing Gland
OM257	OM257	Packing Nut
OM258	OM258	Rotating Index Head
OM259	OM259	* Woodruff Key for Index Head
OM260	OM260	Acorn Nut for Stem
OM261	OM261	Orifice Index (Indicating) Band
OM262	OM262	** Rotating Selector Disc
OM264	OM264	Ring for Selector Disc
OM265	OM265	Spring for Selector Disc
OM266	OM666	* Nuts for Flange/Studs
OM267	OM267	* Screws for Indicator Plate
OM268	OM668	Bottom Body Casting
OM269	OM269	* Center Outlet Tube
OM270	OM670	Studs for Flange/Body (6 req'd)
OM271	OM271	Lock Pins for Orifice Plate (2 req'd)
OM272- _A	OM272- _A	Orifice Plate (Specify 1, 2, 3, or 4)
OM273	OM273	Orifice Plate Stud / Selector Disc Guide
OM274	OM274	Nut for Center Stud
OM275	OM275	Bottom Gasket (2 lock pin holes)
OM276	OM276	Top Gasket
OM278	OM278	Adjustment Pinion Assembly
OM280	OM680	Sediment Chamber Casting
OM281	OM281	* Male Union for Sediment Chamber
OM282	OM282	* Hammer Lug Nut for Union
OM283	OM283	S.S. Cylinder Filter Screen
OM297	OM297	* Double Topped Fitting
* Not shown here.		
** A new OM264 is required when replacing this part.		

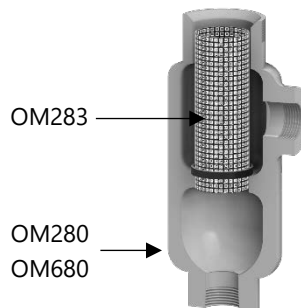

## **Instructions for Installing Continuous Blow-off Piping**

The object of the MADDEN SYSTEM is to continuously remove a high percentage of foreign solids which accumulate in all boilers due to the evaporative process.

The most effective results are obtained when the blow-off pipe is extended into the boiler drum to a point of turbulent flow. Steam bubbles moving upward will carry the suspended solids present to the surface of the water; thus it is desirable to have the blow-off pipe extend inward to, or near, the section of upsurge.

In the instance of single drum boilers or others where it is necessary to install continuous blow-off in the same drum with incoming feed water, the blow-off pipe should be located to bleed from a point as far removed as possible from the feed water inlet; otherwise clear feed water, rather than concentrated boiler water will be removed. Whenever a deflector plate or baffle is installed in the drum, separating the feed water from boiler water, the blow-off pipe should be on the boiler water side of the plate.

As a general rule, one pipe connection into the boiler drum is all that is required. The exceptions to the rule are represented by straight tube boilers with more than one drum, boilers with water walls, or others where the construction is such that circulation of water may follow more than one path or cycle.

### **Relation of Blow-Off Pipe to Surface of Water**

It is usually sufficient to have the blow-off pipe extend 4" to 6" below the normal water line. In a few rare cases, due to some characteristics of the feed water supply or action of circulation in the boiler, it may become necessary to have the blow-off pipe submerged to a depth of 8" or even more.

It is important that the pipe line from the boiler drum to the MADDEN FLOW CONTROL UNIT be of suitable size to

insure adequate flow without excessive pressure drop, or without being so large that velocity is too slow to clear the sludge. Schedule 80 - 3/4" pipe or stronger is recommended, but in no instance should the pipe line be less than 1/2" nor more than 1" pipe size.

The rules of A.S.M.E. Boiler Construction Code stipulate that all blow-off piping shall be constructed of wrought iron or steel of sufficient strength per boiler operating pressure.

The pipe line from the boiler drum to the MADDEN FLOW CONTROL UNIT may be of any length or arrangement which will best suit your convenience. An easy installation is to run the 3/4" pipe to a point directly over the regular blow-off line, then connect the Madden Unit therein at any convenient height. It is not necessary however, that this plan be followed. By observing the following rules, MADDEN UNITS may be installed at any desired location remote from the boiler:

1. MADDEN UNITS may be located at any point which is below the water line in the boiler.
2. When boiler water passes through the orifice, pressure is relieved, and since the stream will carry a high proportion of sludge, it is important that the discharge line be installed to maintain gravity flow; otherwise sludge will be trapped and will clog the discharge line.
3. When two or more units are installed to discharge into a common line, make sure that such line is large enough to carry away the water and sludge without causing excessive back pressure.
4. Always install a shut-off valve of suitable type in the line directly between the boiler and the flow control unit.

## Operating Tips

The MADDEN ORIFICE METER is engineered to withstand the severe service represented by the continuous flow of fluids at high temperature and high velocity. It is heavily constructed to assure a wide margin of safety for pressure work. Every unit is pressure tested to conform with all requirements of the A.S.M.E. Code.

The illustrations will show the principle of operation as well as the component parts. Note that fluid must first pass through a sedimentation chamber. Here, the larger solid particles are screened out and allowed to settle. They are easily removed by means of the sediment valve. A flash opening of this valve, once every 24 hours, is usually adequate. However, this should be regulated according to your boiler room's specific requirements.

Water entering the MADDEN ORIFICE METER will carry all the "fines" that can pass through the stainless steel screen, but nothing large enough to clog the smallest orifice.

The orifices are sized to provide a differential flow rate of approximately 15% graduated progressively from Orifice No. 1 through Orifice No. 17. This makes possible very precise flow regulation as well as a wide range of adjustment.

The selector disc may be rotated by means of the geared pinion and index head of the "Off" position or to any one of the seventeen orifices. When changing from one position to another, always be sure the index number for the required orifice is exactly centered at the indicator plate. This will assure free flow through the orifice and avoid any possibility of jet action or cutting of the parts.

The following table will indicate the approximate total force against the disc:

Pressure 300 PSI - Total force 3,750 lbs.

Pressure 400 PSI - Total force 5,000 lbs.

Pressure 500 PSI - Total force 6,250 lbs.

Pressure 600 PSI - Total force, 7,500 lbs.

**WARNING: To prevent damage to the Orifice Meter when changing from one orifice to another, close the isolation valve on the line coming from the boiler to shut off the pressure on the Orifice Meter. Changing the orifice with the pressure staying on the meter may cause damage to the teeth on the adjustment pinion gear or to the teeth on the rotating index head.**

If, at any time, it should become necessary for the Orifice Meter to be taken apart, great care should be exercised to avoid scratching or marring the lapped surfaces of either the selector disc or the orifice plate. When reassembling the unit, be sure to have both the lapped surfaces absolutely clean and free from dust or other grit.

The selector disc is centered by means of a stainless steel stud, securely attached to the orifice plate, and then lapped surfaces are always held in sealing contact by a stainless steel compression spring.

The stainless steel stem for rotating the selector disc is keyed to the geared index head but is not attached to the selector disc. It is made to engage the selector disc by means of a milled slot. This permits rotation of the disc without danger of disturbing sealing contact with the orifice plate. Note that the stem will seat in only one position in relation to the selector disc.

Whenever it becomes necessary to adjust the packing or repack the stem, this may be easily accomplished as follows:

1. Remove the acorn nut on top of the geared index head.
2. Lift the geared index head from the stem. This will expose the packing nut which may then be turned down to compress the packing rings, or removed from re-packing the gland.

If it should be necessary to remove the stem, in replacing it, be sure it will fully engage the milled slot in the selector disc before repacking the gland.

## Hot Torque Instruction

The Madden Orifice Meter is assembled and tested for leaks at the factory before shipment. However, when the metal material of the Orifice Meter is placed in service and warms up to operating temperature, leaks may develop. To help prevent leaks, use the "Hot Torque" procedure that follows.

1. Retorque the six flange nuts while the unit is at operating temperature 12-24 hours after the unit is placed in service.
2. Close the isolation valve to remove the boiler pressure from the Orifice Meter.
3. Retorque the nuts in a star pattern.
  - a. First at 1/3 torque
  - b. Then at 2/3 torque
  - c. Finally at full torque per the following torque specifications

MODEL	1/3 Torque	2/3 Torque	Full Torque
OM250	20 ft. lbs.	40 ft. lbs.	60 ft. lbs.
OM650	40 ft. lbs.	80 ft. lbs.	120 ft. lbs.

4. After full torque is applied to all the flange nuts, open the isolation valve to put the Orifice Meter back into service.
5. If the Orifice Meter is taken out of service for repairs, the reassembly must include a heavy graphite filled oil lubricant for the nuts and the threaded studs. For "cold" bench assembly, hand tighten the nuts and then torque the nuts per the specifications above. Hot torque after 12-24 hours of service.
6. If leaks develop from under the geared index head, (part number OM258), remove the index head by removing the acorn nut, (part number OM260). Tighten the packing nut, (part number OM257), until the leak is stopped. Replace the index head, key and nut. If a leak continues, remove the Orifice Meter from service and replace the stem packing (part number OM255).