

MADDEN

ENGINEERED PRODUCTS

Boiler Blowdown Heat Recovery Systems

***Reduces Boiler Fuel Consumption
& Carbon Footprint***



***Type HC – Horizontal Type:
Large Capacities***

- Pg 1** Part Number Format
- Pg 2** Madden H.R.S. Benefits
- Pg 3** HC Model Overview
- Pg 4** Performance & Savings Example
- Pg 5** Product Selection & Dimensions
- Pg 6** Common Ancillary Equipment

Madden Heat Recovery Systems

Part Numbering Format

Format: 1st - start with HV, HC, HX, or HVX. 2nd - add capacity number. 3rd - add ancillary equipment adders and upgrades as necessary.

1.) "HV" SERIES VERTICAL, COMPACT	2.) "HC" SERIES HORIZONTAL, HIGH CAPACITY	3.) "HX" SERIES SMALL, EFFICIENT, COST EFFECTIVE
BLOWDOWN CAPACITIES "30" - 3,000 PPH "50" - 5,000 PPH "70" - 7,000 PPH "90" - 9,000 PPH "120" - 12,000 PPH	BLOWDOWN CAPACITIES "40" - 4,000 PPH "80" - 8,000 PPH "120" - 12,000 PPH "160" - 16,000 PPH "200" - 20,000 PPH "240" - 24,000 PPH "280" - 28,000 PPH "320" - 32,000 PPH "360" - 36,000 PPH "500" - 50,000 PPH	BLOWDOWN CAPACITIES "20" - 2,000 PPH * "25" - 2,500 PPH * "30" - 3,000 PPH *
		4.) "HVX" SERIES HV / HX HYBRID
		BLOWDOWN CAPACITIES "15" - 1,500 PPH

*NOTE: HX series heat exchangers do not offer flash steam recovery.

-
OPTIONAL ANCILLARY EQUIPMENT '<u>ADDITIONS</u>'
"H" - HIGH LEVEL ALARM SYSTEM, P/N HC002B, (HV & HC SERIES) "I" - CUSTOM FIT ISULATION JACKET, P/N HV50(CAPACITY)IJ, (ALL) "A" - COPPER COIL HEAT EXCHANGER - shorter service life, more efficient BTU recovery (HV & HX SERIES) "O" - MADDEN ORIFICE METER(S), P/N OM250_A OR OM650_A, - for blowdown flow rate control. "M" - INLET MANIFOLD, P/N HV310, 3" X 36", Sch 80, SA106 or A53, CS, up to (3) 1" FNPT connections.
-
OPTIONAL ANCILLARY EQUIPMENT '<u>UPGRADES</u>'
"1" - EXTERNAL LEVEL CONTROLLER - Armstrong liquid lever drain trap, in lieu of Madden's standard internal float and drain controller. (HC & HV SERIES) "2" - ELEVATED STAND - 2" x 2" steel tubing frame connected to upper vessel for easy maintenance of lower heat exchanger. (HV SERIES ONLY).

Full P/N Example:

HV50	-	HIOM	-	2
------	---	------	---	---

Madden Benefits

Three different styles and twenty standard models are available to match a Madden Blowdown Heat Recovery System to your boiler system for the best performance and the most economical return on investment. Look at these Madden results:

- *Recover 90% of the heat energy in continuous top blowdown that would be lost down the drain*
- *Reduce temperature of blowdown discharge to drain to meet statute limits*
- *Fast investment payback from fuel, cooling water and makeup water savings, Madden systems usually pay for themselves in less than 12 months*
- *Durable, time proven designs, built to take the punishment of continuous, 24 hour a day service for years.*

How does it work?

Hot, high pressure continuous blowdown water drained from the boiler contains valuable heat energy. The continuous blowdown process helps control boiler water quality and operating efficiency by removing suspended and dissolved solids from the water in the boiler drum.

Recovery of up to 50% of the BTU's available may be accomplished by generating low pressure flash steam in a flash tank. This supply of steam can be used in the boiler D/A tank or other low pressure steam applications. As the flash steam is generated, the blowdown condensate that remains is used to preheat the boiler feed water using a low-pressure liquid to liquid heat exchanger. For smaller, lower pressure blowdown requirements, the HX Series heat recovery systems utilize a higher-pressure liquid to liquid heat exchanger without a flash tank to do the heat recovery job. The Madden sales representative will recommend the model you need to maximize your fuel savings potential.

What is Continuous Top Blowdown?

To prevent scale buildup and to ensure high steam quality and boiler operating efficiency, boiler water quality specifications must be maintained. Chemical treatment alone can't do the job, so water containing concentrated dissolved and suspended mineral solids is removed continuously through a top blowdown system. As the dirty blowdown water is removed from the boiler drum, it is replaced with fresh makeup water which improves the boiler water quality. Too much blowdown wastes heat and chemical treatment. Too little blowdown results in operation and maintenance problems. To get the full benefits of blowdown heat recovery, the blowdown flow must be continuous, not intermittent.

Madden System Features

Type HV and Type HC

- **No Solids Buildup.** Madden systems are self-flushing, designed to use gravity flow to continuously clean itself. They operate without becoming clogged or fouled with solids contained in the dirty blowdown water.
- **Low pressure heat exchangers** in the Type HC and Type HV systems – this reduces stress on equipment and makes scale buildup unlikely on the cooling side of the heat exchanger tubes. This is because the temperature rise of the makeup water cooling medium will usually be no more than 20 degrees Fahrenheit.
- **Flash Tanks** designed for blowdown – baffles on the blowdown inlet create water droplets and turbulence to enlarge the surface area and increase flashing. Adequate vessel volume produces clean steam without water carryover. Surface area and retention time are engineered to facilitate flashing.

Madden Features – Type HC

Madden Type HC Continuous Boiler Blowdown Heat Recovery Systems feature blowdown capacities up to 50,000 lbs per hour. Special designs for capacities up to 60,000 lbs per hour are also available. (See page 7 for dimensions).

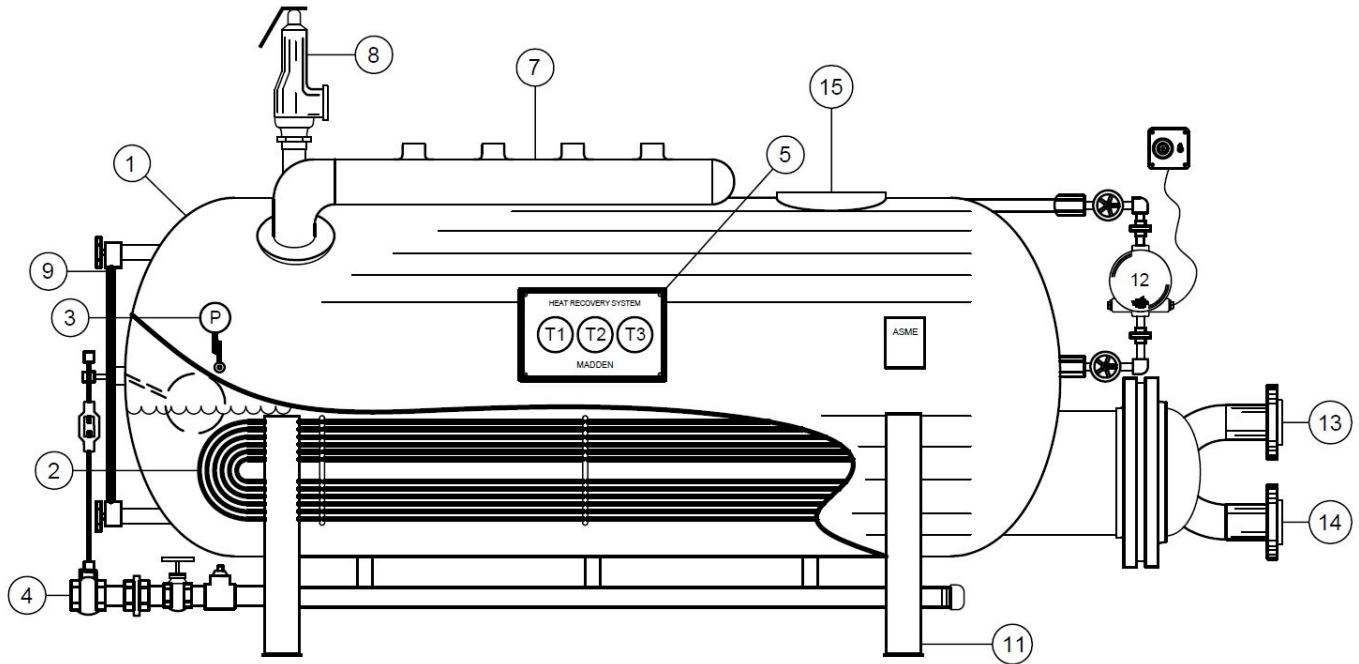

1. ASME code welded combined flash tank and heat exchanger vessel 150 psi construction.
2. U tubes of type 304 stainless steel. Tubes can be easily removed for inspection, cleaning and replacement.
3. Pressure gauge.
4. External float valve of balanced pressure design. Only float mechanism is inside flash tank. Maintains sufficient blowdown water level in the flash tank to cover exchanger tubes at all times.
5. Temperature gauge panel continuously shows performance of unit and furnishes data to calculate savings.
6. Orifice meter flow controls (see page 9) are precision instruments that accurately control the rate of blowdown. Proven in thousands of installations (Available as an option).
7. Customized inlet flow control manifold. Six boilers or more can easily be tied into one heat recovery system.
8. Relief Valve.
9. Gauge glass set.
10. 6" x 8" Hand hole for inspection.
11. Heavy duty saddle type mounting base.
12. High level float with alarm (optional).
13. Makeup water inlet flanged connection.
14. Makeup water outlet flanged connection.
15. Flanged flash steam vent connection.

Dimensions Type HV Heat Recovery Systems



Dimensions Type HC Heat Recovery Systems

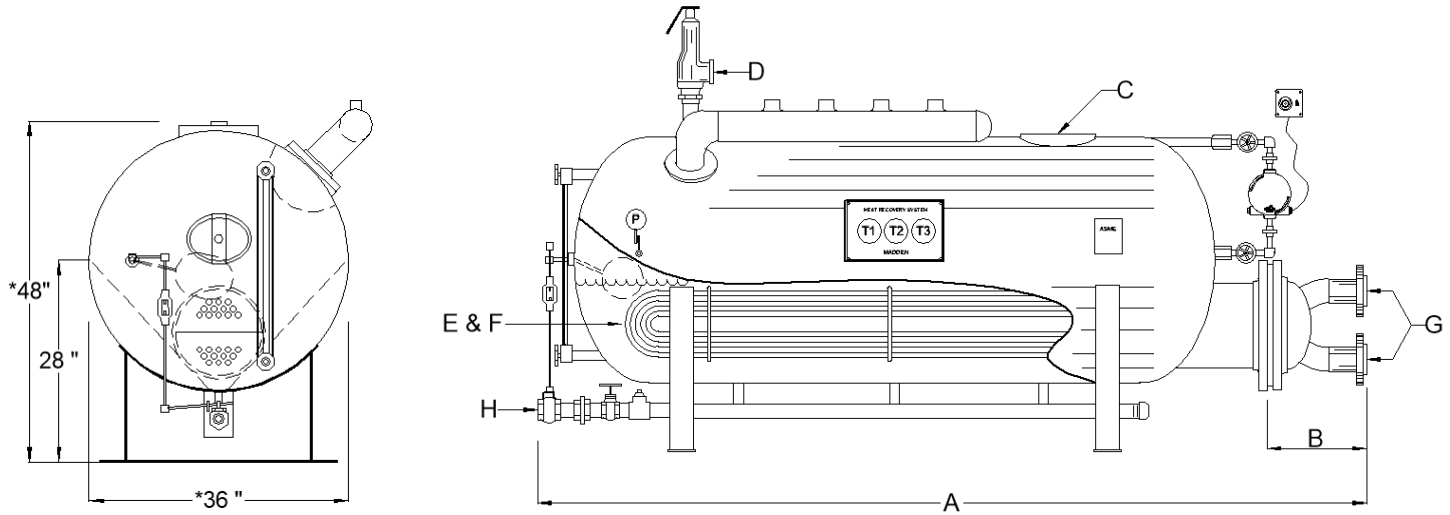

Model No.	HC 40-150	HC 80-150	HC120-150	HC160-150	HC200-150	HC240-150	HC280-150	HC320-150	HC360-150	*HC500-150
Blowdown Capacity (PPH)	4,000	8,000	12,000	16,000	20,000	24,000	28,000	32,000	36,000	50,000
A – (OAL)	64"	70"	75"	87"	99"	111"	130"	142"	154"	138"
B	8"	8"	13"	13"	13"	13"	20"	20"	20"	22"
C – (Vent)	3"	4"	4"	6"	6"	6"	8"	8"	8"	8"
D – (PRV Outlet)	2"	2-1/2"	3"	3"	4"	4"	4"	4"	4"	6"
E – (# of Tubes)	30	30	45	45	45	45	45	45	45	63
F – (HX Area SF)	44	47	79	97	115	132	150	168	186	250
G – (Inlet/Outlet)	3"	3"	4"	4"	4"	4"	6"	6"	6"	6"
H – (Drain)	1"	1"	1-1/4"	1-1/2"	1-1/2"	2"	2"	2"	2"	2"
Ship Weight	1,000 lbs.	1,200 lbs.	1,400 lbs.	1,900 lbs.	2,300 lbs.	2,700 lbs.	3,100 lbs.	3,500 lbs.	3,900 lbs.	4,500 lbs.

*NOTE: These dimensions do not account for ancillary equipment and they are specific to models HC40 through HC360. The HC500-150 is 48" wide X – 66" tall.

Madden Ancillary Equipment



Orifice Meter - Flow Control Option

The adjustable Madden Orifice Meter has 17 different orifices to select for accurate blowdown flow control. Durable, guaranteed for 10 years against cutting, wire drawing, or other distortion. One unit required for each boiler.

The Madden Orifice Meter enables the boiler operator to maintain accurate, repeatable flow control for continuous top blowdown.

Two models:

- OM250 – for boilers up to 250 psi.
- OM650 – for boilers up to 650 psi.

Features include:

- Sediment chamber w/stainless steel filter screen.
- Removable adjustment key.
- Stainless steel, heat-treated orifice plate.
- Drain valve and flush filter screen.

High Level Switch and Alarm System

All heat recovery systems, less the 'original' HX series, have an optional high-level switch and alarm system (P/N HC002B). Madden typically uses a Mercoid 123 series SPDT switch with our alarm box. The switch enclosure is "general purpose". Other switches can be sourced upon request.

The alarm box is a 4" x 4" x 4" PVC wall mount box (NEMA 4X) with manual silencing toggle switch. It is wired to blink the light and sound the alarm. Contractors can connect to the same alarm contact to then wire an external output signal elsewhere at the job site.

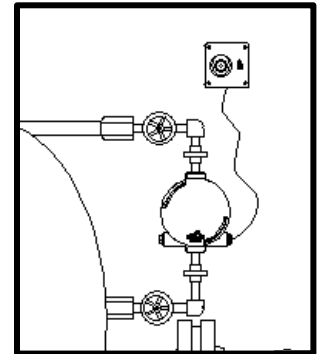

Custom Insulation Jackets – Cost efficient and easy to install.

Madden offers M.I.T. International insulation jackets to further boost the energy efficiency of our heat recovery systems. The jackets are built to order to fit your particular HV, HC, or HX system. They fit around all connections and come with Velcro straps and hog ring ties to further secure the jacket to the system.

This material has a durable silicone interior and exterior cloth with 1" thick insulation. Rated to 500 deg F.

Not only will this material increase your system's efficiency, it also protects local personnel from accidentally touching the units when operating.



MADDEN
ENGINEERED PRODUCTS

P.O. Box 387
1317 Princeton Blvd.
Elkhart, Indiana 46516

SOLD BY:

Phone: (574) 295-4292
Fax: (574) 295-7562
Email: info@maddenep.com